

MASTERDRIVES VC

"Free blocks" function diagram

Status: 31.01.98

- Notes:
- A free block is only processed if it is specifically assigned to a sampling time via the allocated U95x parameter; see sheet [702]!
 - Parameterization of the sampling sequence is also described on sheet [702]
 - The approximate calculating time per block is indicated in { μ s} for each type of block.
 - Siemens is working on an optimization run for the sampling sequence.

1

2

3

4

5

6

7

8

Setting and monitoring the sampling times and sampling sequence

Function	Function block number	Sampling time U950...U953 (20)		Sampling sequence U960...U963	
		Parameter No. (factory setting)		Parameter No. (factory setting)	
Processing of input terminals and receive data from serial interfaces	001	U950.01	(20)	U960.01	(0010)
	002	U950.02	(20)	U960.02	(0020)
	...				
	019	U950.19	(20)	U960.19	(0300)
Processing of output terminals and transmit data to serial interfaces	20	U950.20	(20)	U960.20	(9990)
				
	29	U950.29	(20)	U960.29	(9999)
Free function blocks	031	U950.31	(20)	U960.31	(0310)
	032	U950.32	(20)	U960.32	(0320)
				
	099	U950.99	(20)	U960.99	(0990)
	101	U951.01	(20)	U961.01	(1010)
	102	U951.02	(20)	U961.02	(1020)
				
	330	U953.30	(20)	U963.30	(3300)
Angle synchronism and positioning	331	U953.31	(20)	U963.31	(3310)
				
	350	U953.50	(20)	U963.50	(3500)
Internal sequence control and setpoint calculation	351	U953.51	(20)	U963.51	(3510)
				
	370	U953.70	(20)	U963.70	(3700)
Reserve	371	U953.71	(20)	U963.71	(3710)
				
	399	U953.99	(20)	U963.99	(3990)

Example of the sampling time and sampling sequence of a function block:

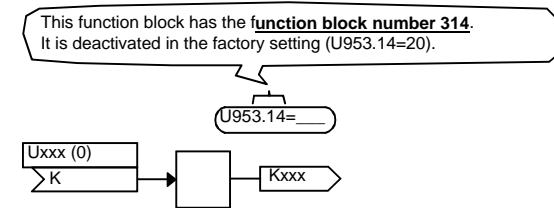

Via **U953.14=4** the function block can be allocated to the **sampling time** T4 (= 16 * T0 = 1.6 ms at 10 KHz pulse frequency).

The function block is processed in the factory setting at the 3140th position. By setting **U963.14** to a value not equal to 3140, the block can be allocated to a different position in the **sampling sequence**.

Monitoring of calculating time

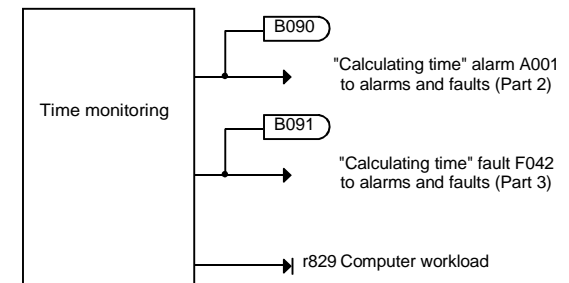

Parameters for setting the sampling time		
Value range : 2 ... 20		
Factory setting : 20 (block is not calculated)		
Parameter value	Sampling time (T0 = 1/pulse freq. = 1/P340)	Sampling time at 10 KHz pulse frequency (T0=100µs)
2	T2 = 1 * T0	1.2 ms
3	T3 = 2 * T0	2.4 ms
4	T4 = 4 * T0	4.8 ms
5	T5 = 8 * T0	9.6 ms
6	T6 = 16 * T0	19.2 ms
7	T7 = 32 * T0	38.4 ms
8	T8 = 64 * T0	76.8 ms
9	T9 = 128 * T0	153.6 ms
10	T10= 256 * T0	307.2 ms
11 ... 19	Reserved for future applications	
20	Block is not calculated	

Parameter for setting the **sampling sequence**:
Value range : 0 ... 9999
Factory setting : Function block number * 10 ,
i.e. in the factory setting the blocks are processed in the sequence of the block numbers.

9 fixed setpoints (1-word) {2μs}

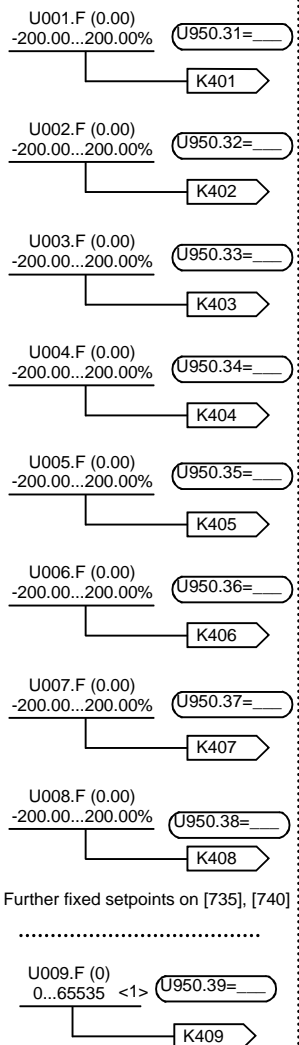

<1> corresponds to -200...200%
Further fixed setpoints on [785]

8 fixed setpoints (2-word) {2μs}

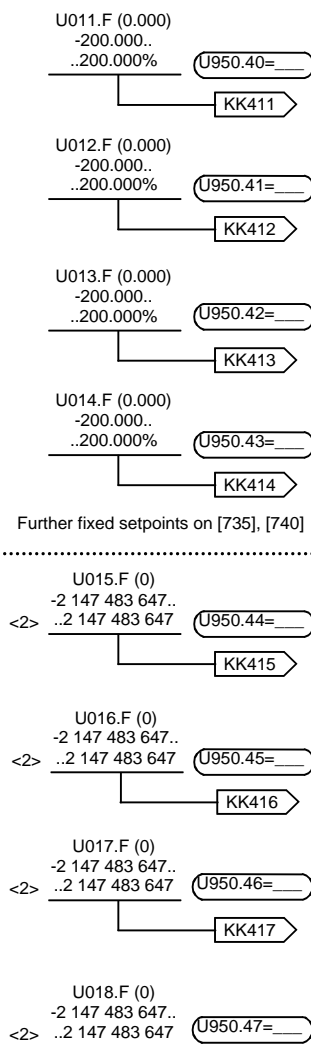

<2> corresponds to -200...200%

8 fixed control bits {2μs}

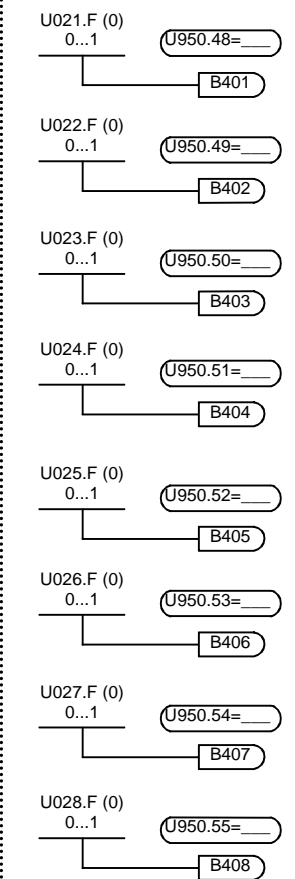

3 connector displays {1μs}

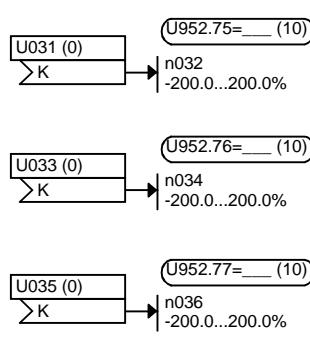

4 double connector displays {3μs}

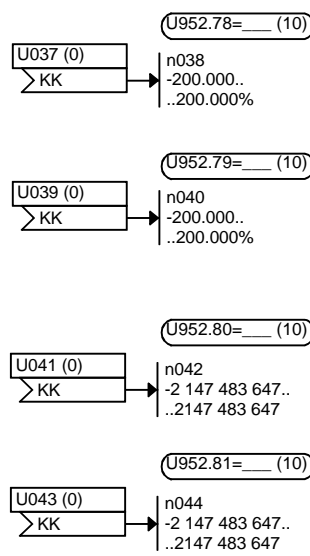

4 binector displays {1μs}

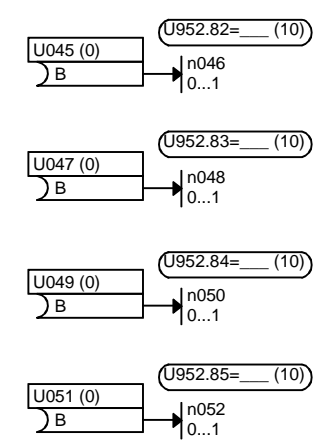

1 connector display with smoothing {5μs}

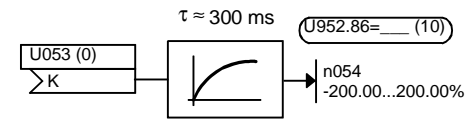

1 double conn. display with smoothing {8μs}

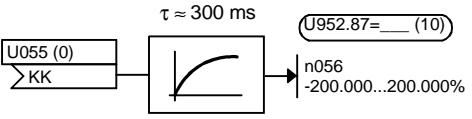

4 fault message trigger signals {2µs}

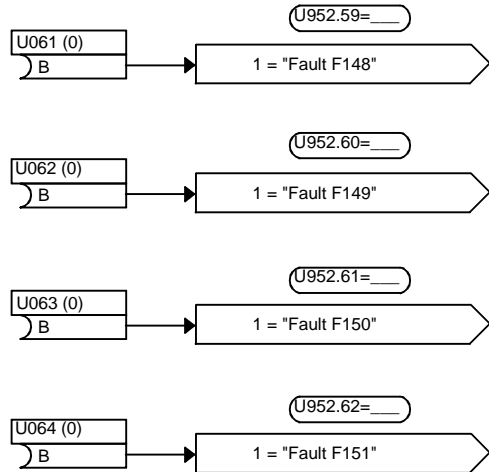

4 alarm message trigger signals {2µs}

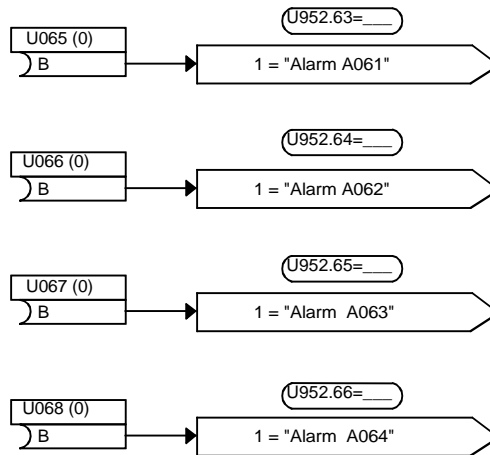

3 connector/double connector converters {9µs}

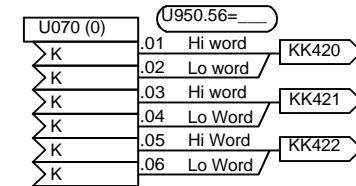

Voltage monitoring of electronics power supply

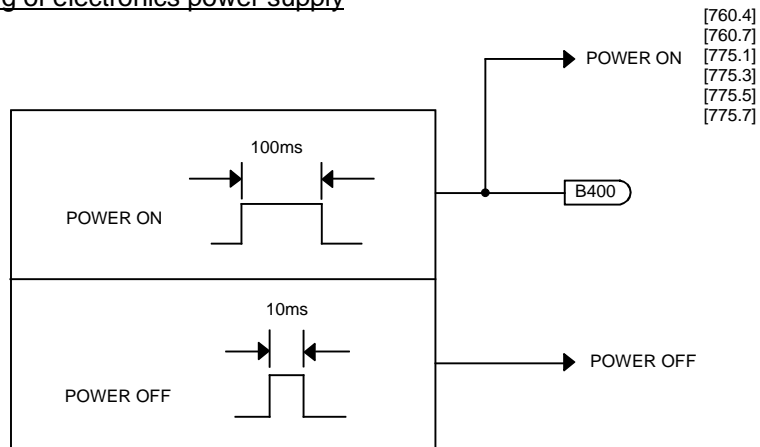

3 double connector/connector converters {11µs}

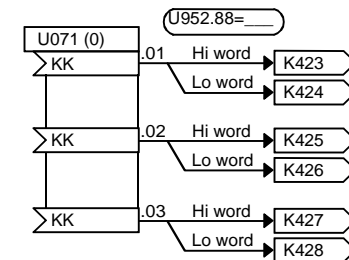

3 connector/binector converters {11µs}

<1> 7-segment display of bit fields to n073, n074 and n075

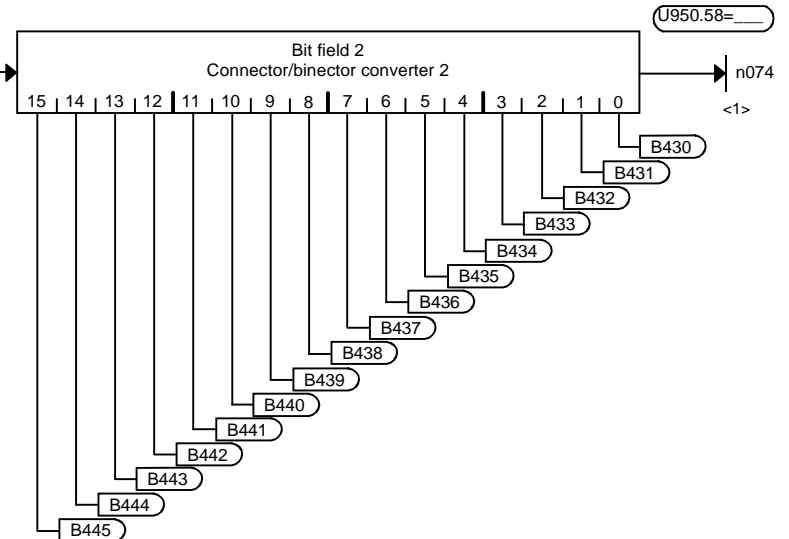
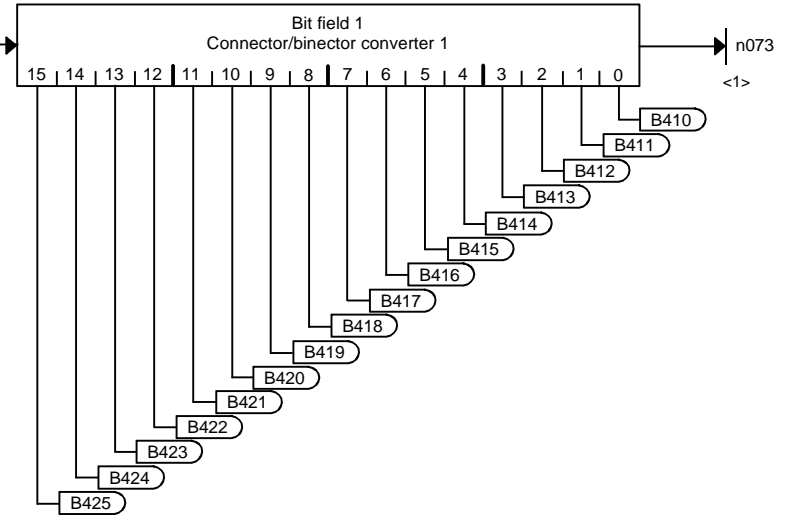
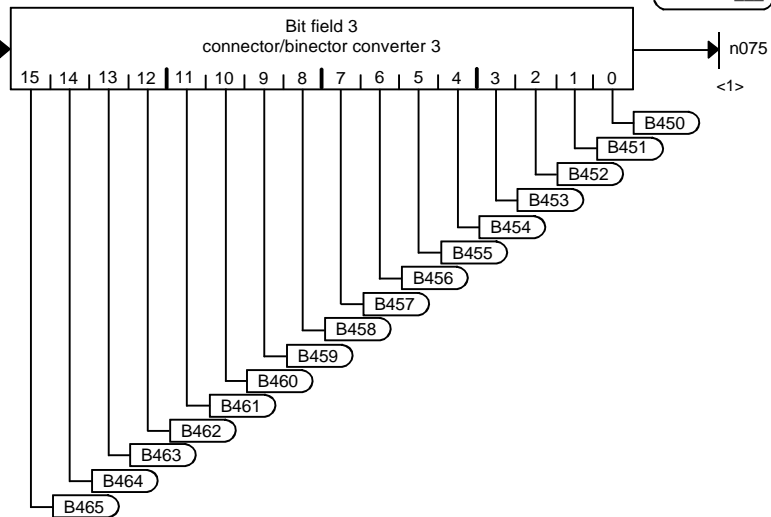
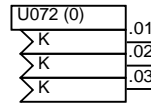
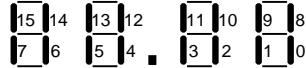

3 binector/connector converters {12µs}

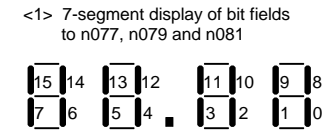
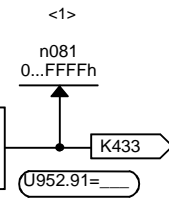
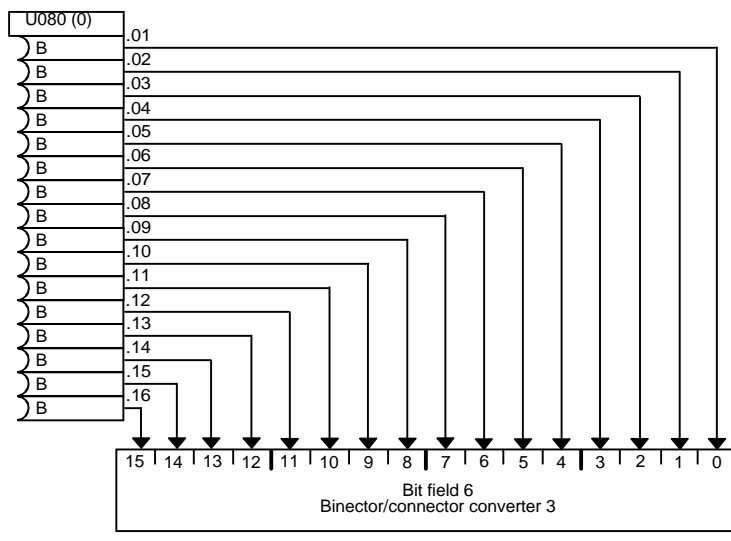
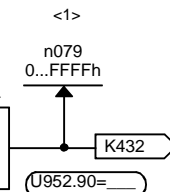
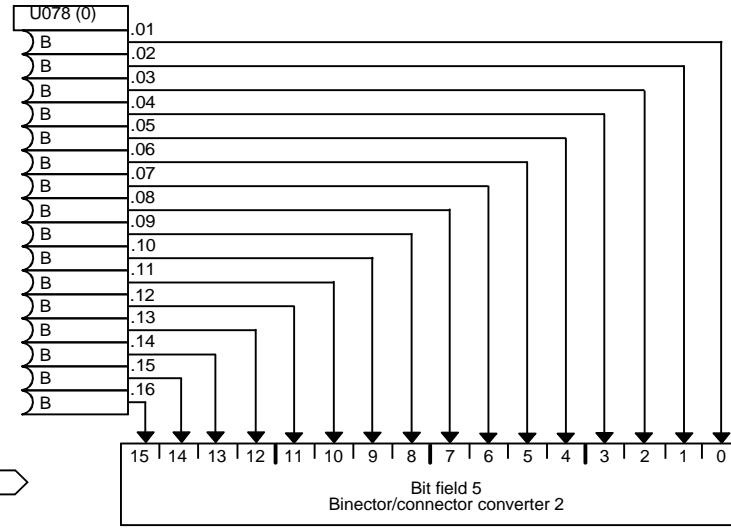
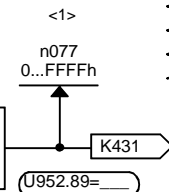
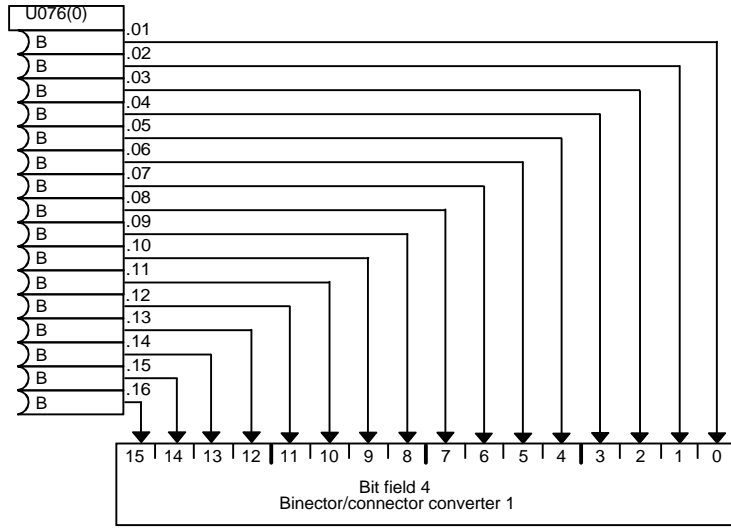

4 adders with 2 inputs
(1-word) {3μs}

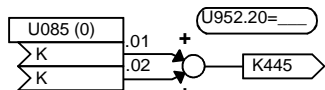
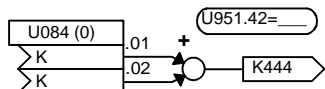
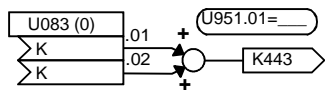
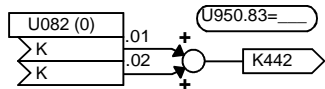

1 adder with 4 inputs
(1-word) {7μs}

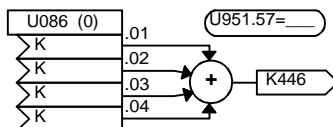

3 subtractors (1-word) {3μs}

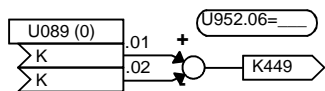
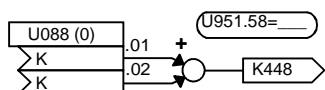
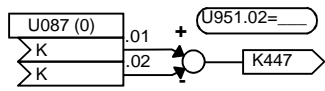

4 adders with 2 inputs
(2-word) {6μs}

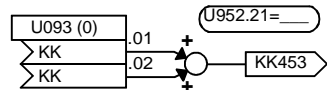
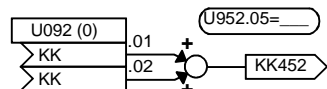
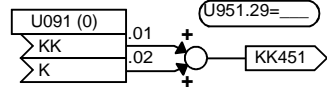
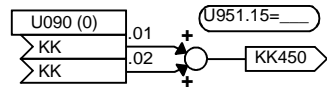

2 subtractors (2-word) {6μs}

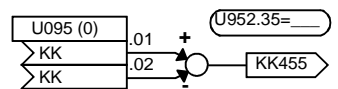
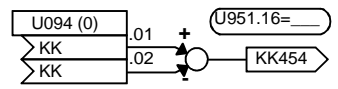

3 sign inverters
(1-word) {2μs}

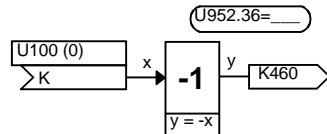
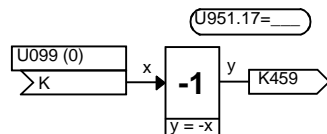
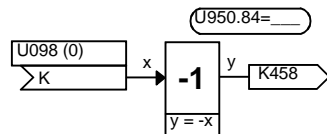

2 sign inverters
(2-word) {4μs}

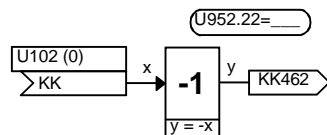
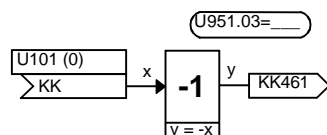

1 switchable sign inverter
(1-word) {2μs}

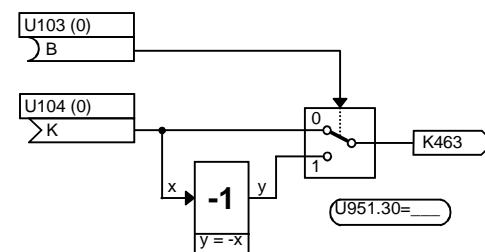

1 switchable sign inverter
(2-word) {4μs}

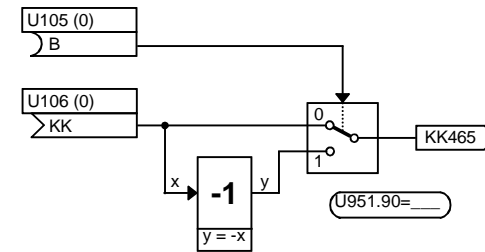

1 modulo 2^16 adder/subtractor {2μs}

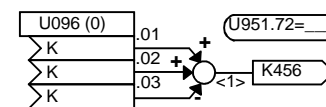

1 modulo 2^32 adder/subtractor {7μs}

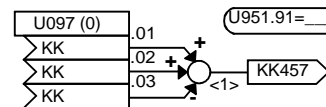

<1> Arithmetic two's complement without evaluation of carry and borrow: No limitation in the case of overflows and underflows outside of the number range of 16 or 32 bit.
(Example: 65535+40000=39999 at modulo 2^16 addition)

3 multipliers (1-word) {12μs}

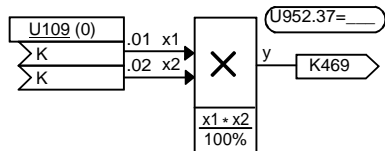
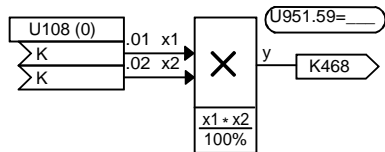
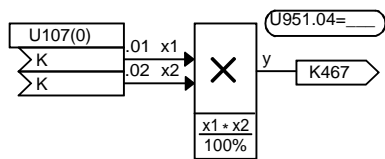

1 multiplier (2-word) {33μs}

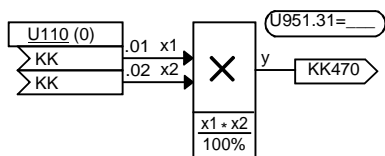

2 dividers (1-word) {15μs}

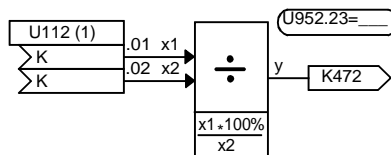
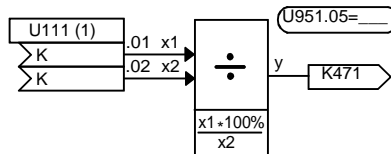

1 divider (2-word) {70μs}

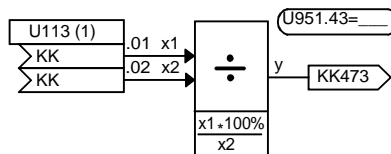

when divided by 0 (x2 = 0):
 when x1 > 0: y = +199.99%
 when x1 = 0: y = 0.00%
 when x1 < 0: y = -199.99%

3 high-resolution multipliers/dividers (1-word) {18μs}

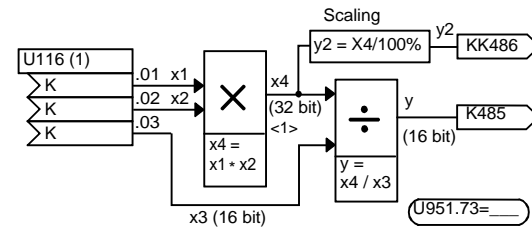
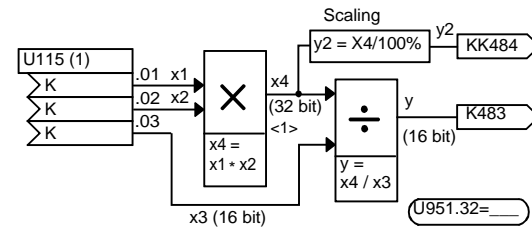
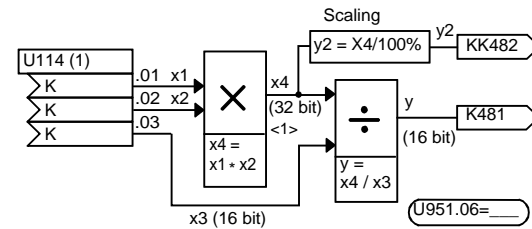

Examples:

When divided by 0 (x3 = 0):
 when x4 > 0: y = +199.99%
 when x4 = 0: y = 0.00%
 when x4 < 0: y = -199.99%

x1	x2	x3	y
100%	100%	100%	100%
100%	40%	50%	80%
-200%	-200%	-200%	-200%

<1> Value range of x4 corresponds to -400% ... +400%; it is restricted at KKxxx to the range -200%...+200%

3 absolute-value generators with smoothing(1-word) {7µs}

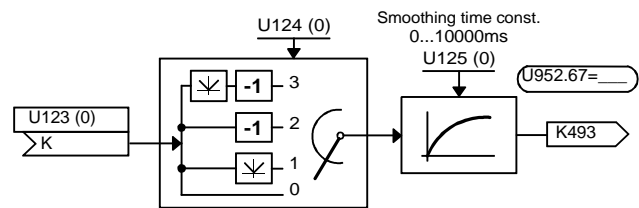
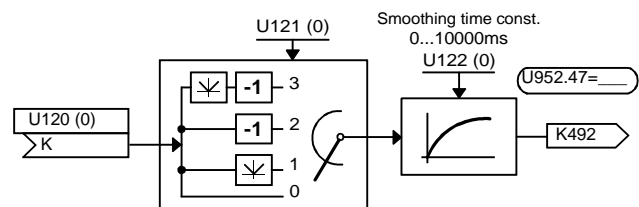
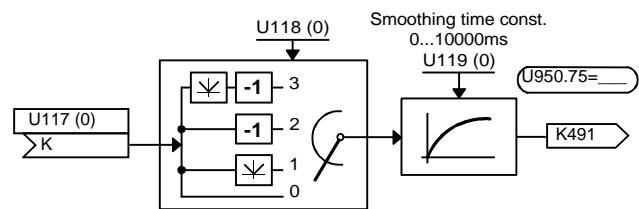

1 absolute-value generator with smoothing (2-word) {10µs}

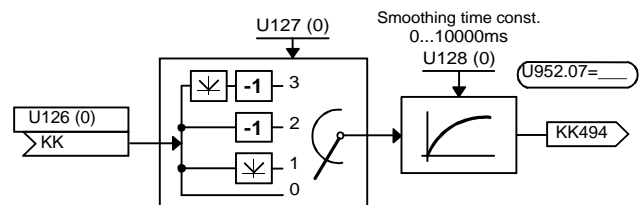

2 limiters (1-word) {5µs}

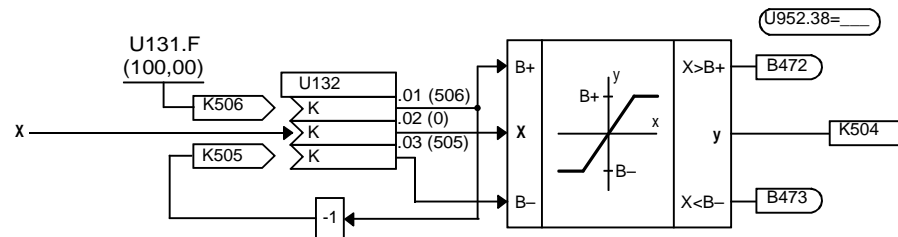
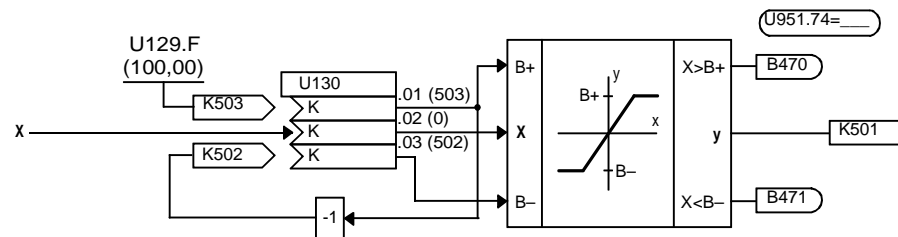

1 limiter (2-word) {11µs}

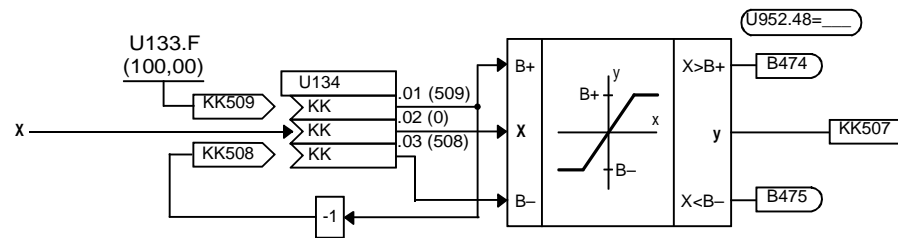

2 limit-value monitors with smoothing (1-word) {15µs}

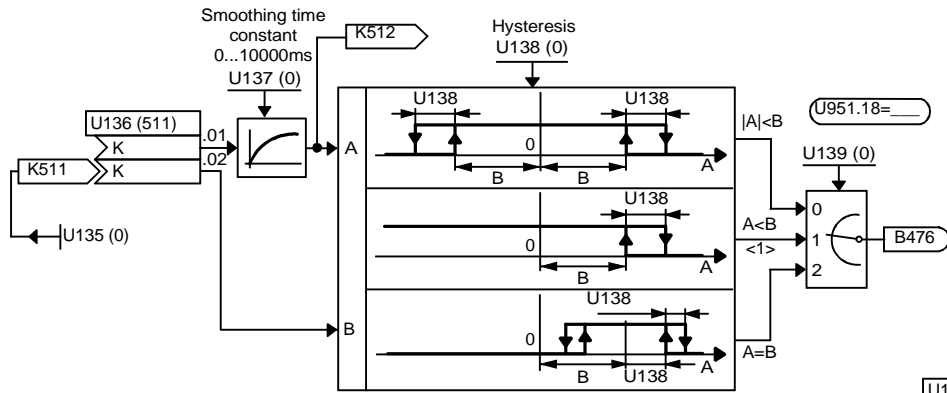

1 limit-value monitor with smoothing (2-word) {24µs}

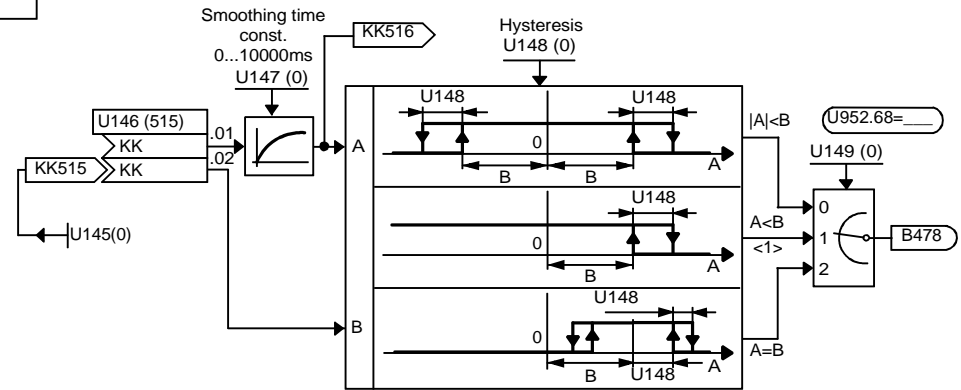

1 limit-value monitor without smoothing (2-word) {18µs}

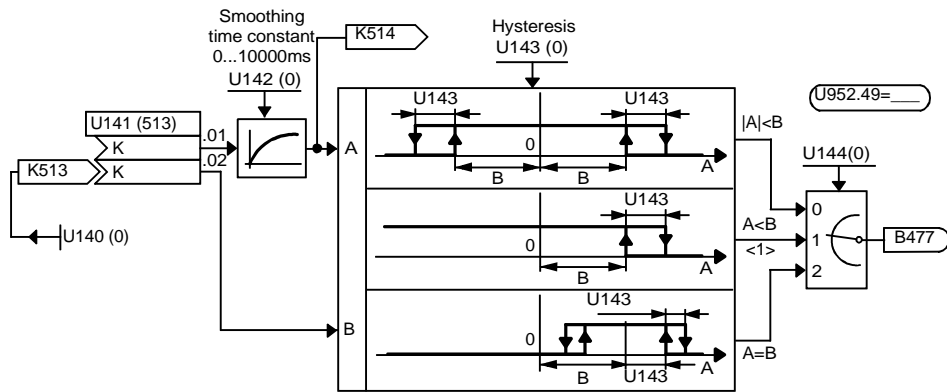
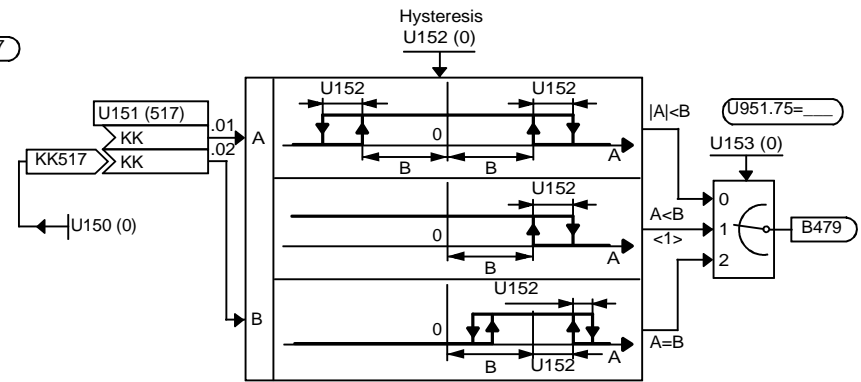

<1> Example: -50% < -40%

2 cam-contactor groups each with 2 cams (2-word) {9μs}

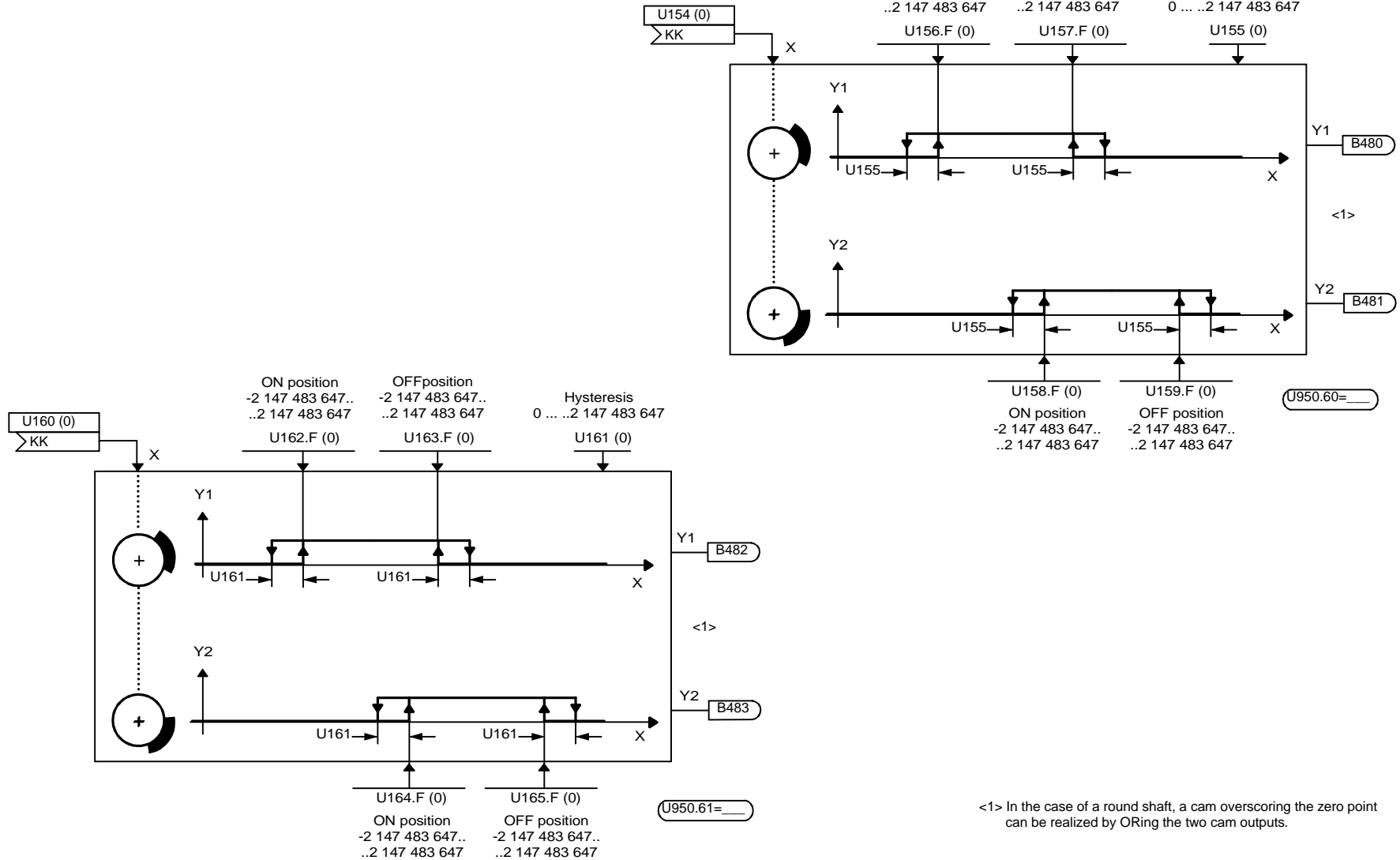

5 Analog signal switches (1-word) {2μs}

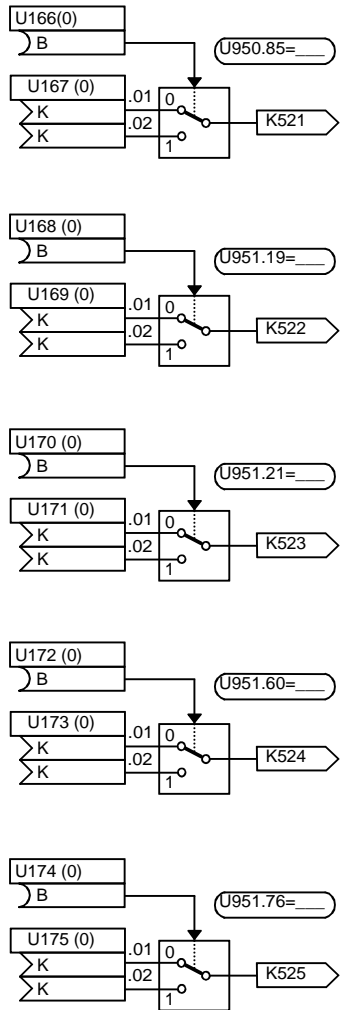

5 Analog signal switches (2-word) {4μs}

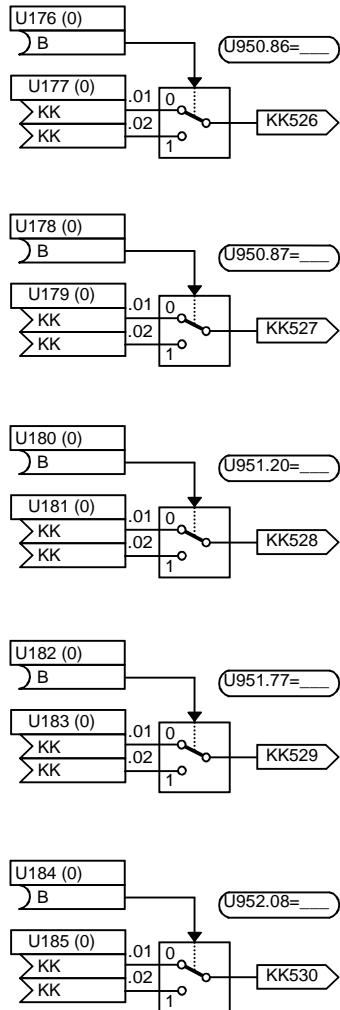

Analog signal multiplexer with 8 channels (2-word) {6μs}

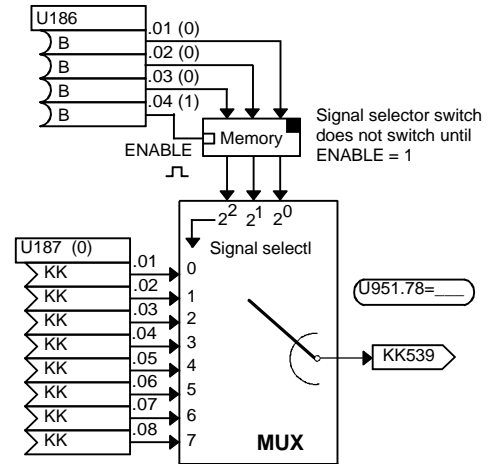

Analog signal demultiplexer with 8 channels (2-word) {8μs}

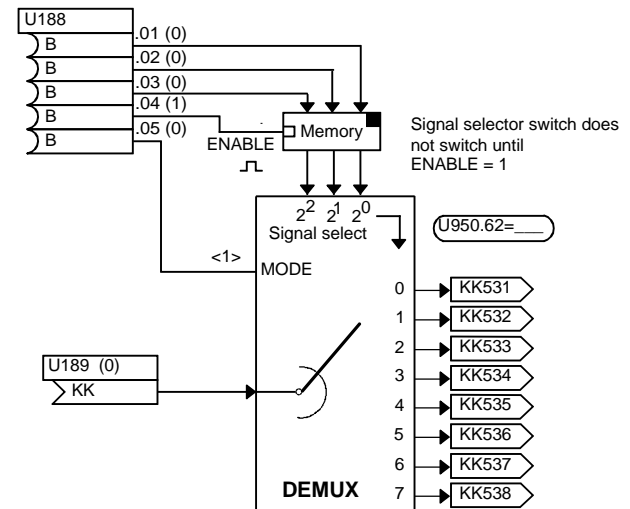

<1> MODE=0: The 7 non-through-connected output connectors are each permanently assigned to the value "0"
 MODE=1: The 7 non-through-connected output connectors remain "frozen" at the old value.

3 characteristic blocks (1-word)
with 10 support values {15μs}

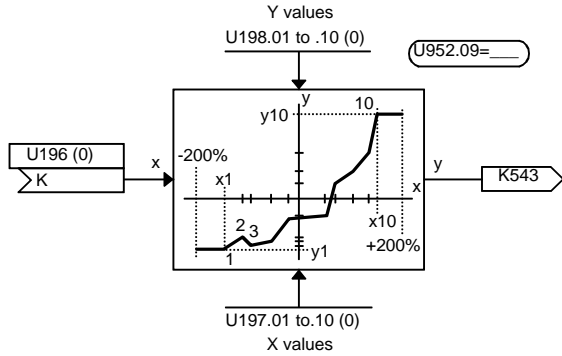
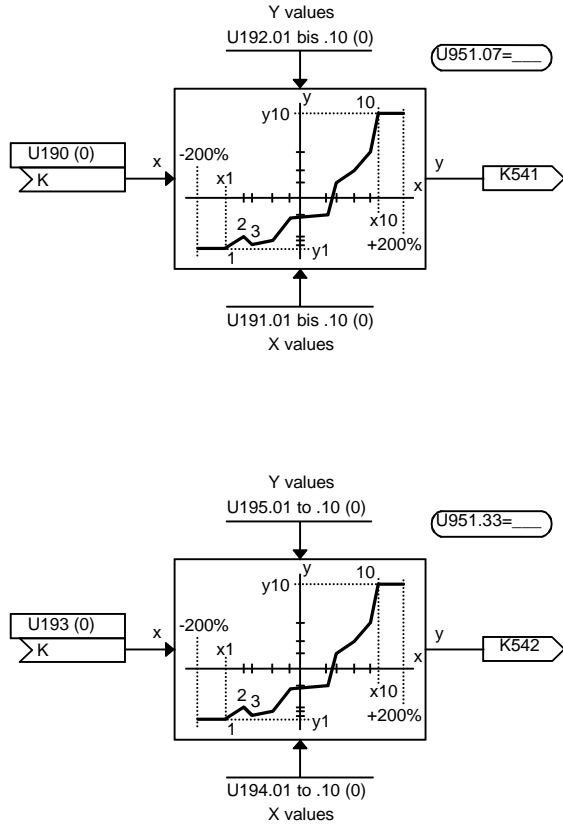

<1> The distance between 2 adjacent X or Y values must not be more than 199.99%.

1 dead zone (1-word) {2μs}

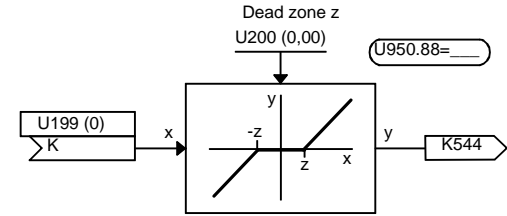

Maximum selection (2-word) {8μs}

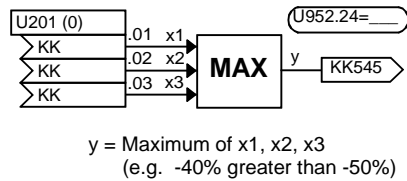

2 tracking/storage elements (2-word) {6μs}

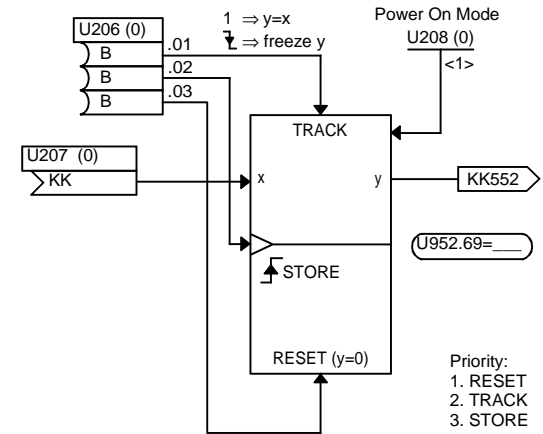
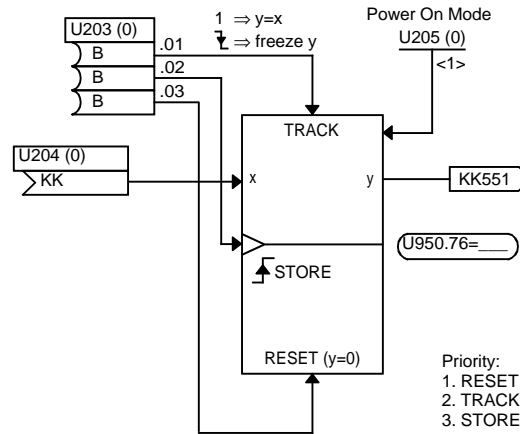

<1> Power On Mode: U205/U208=0: No "non-volatile" storage:
Zero appears at output on voltage recovery.
U205/U208=1: "Non-volatile" storage:
On disconnection or failure of voltage supply, the current output value
is stored and output again upon voltage recovery.

Minimum selection (2-word) {8μs}

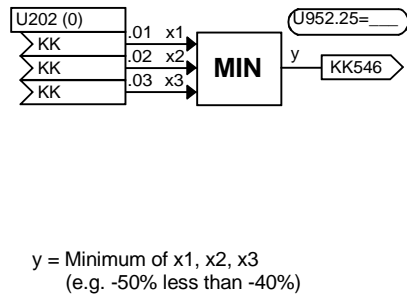

2 analog signal storages (2-word) {4μs}

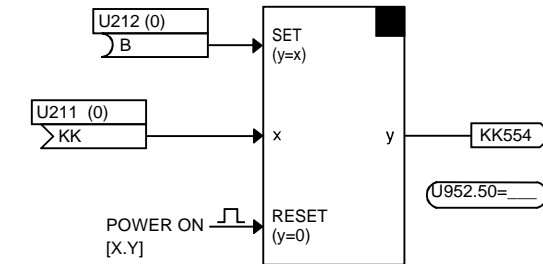
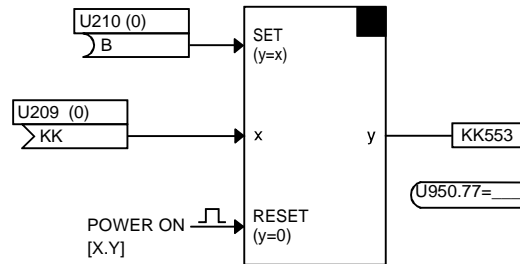

18 AND elements with 3 inputs each {3μs}

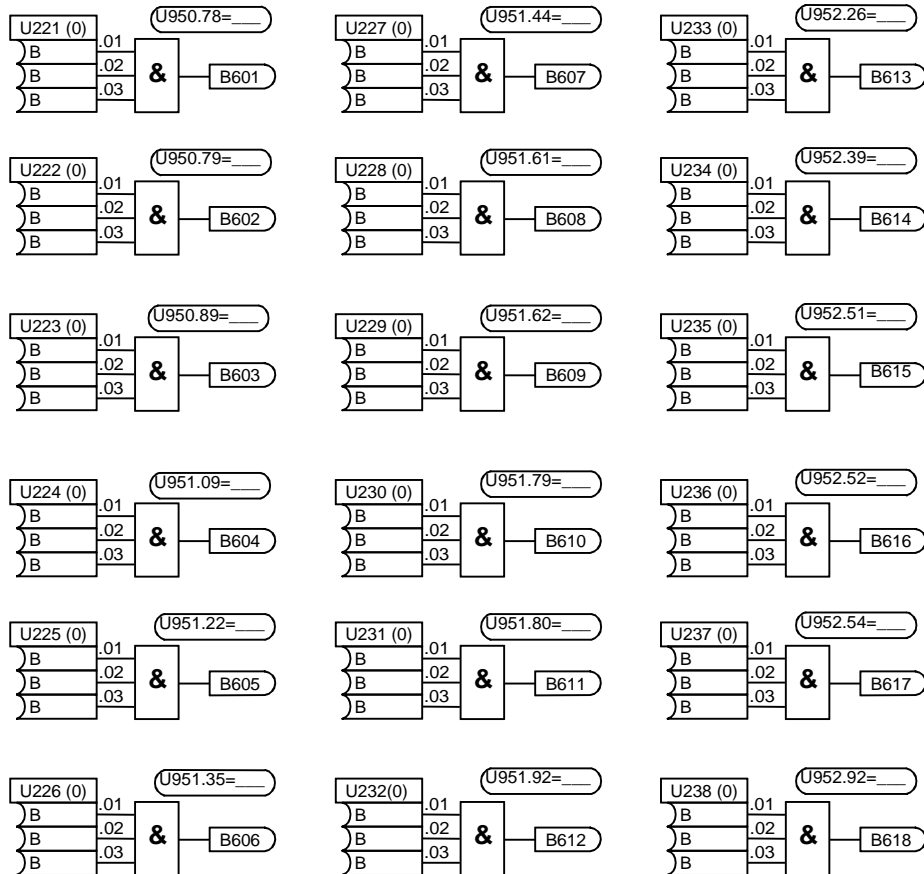

12 OR elements with 3 inputs each {3μs}

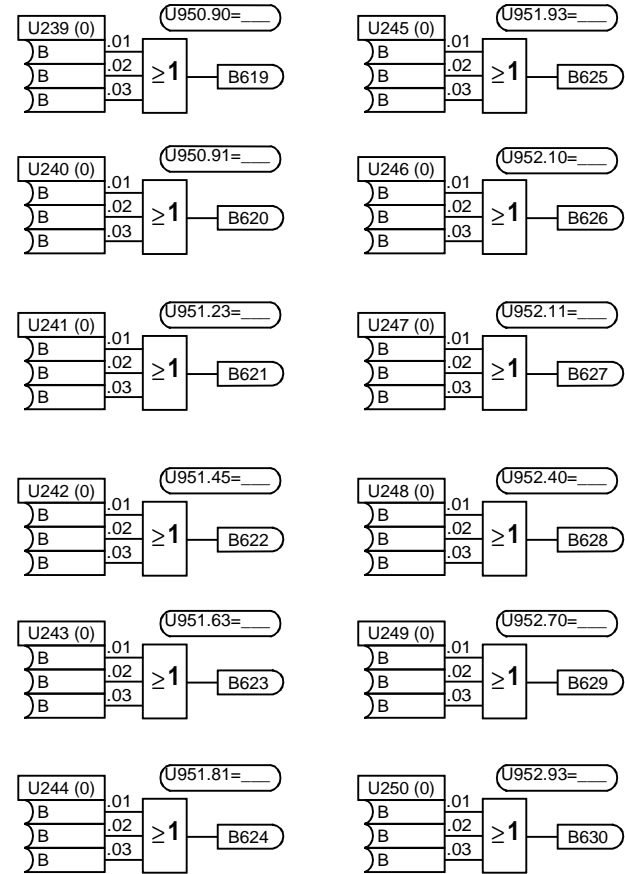

1

2

3

4

5

6

7

8

10 inverters {2μs}

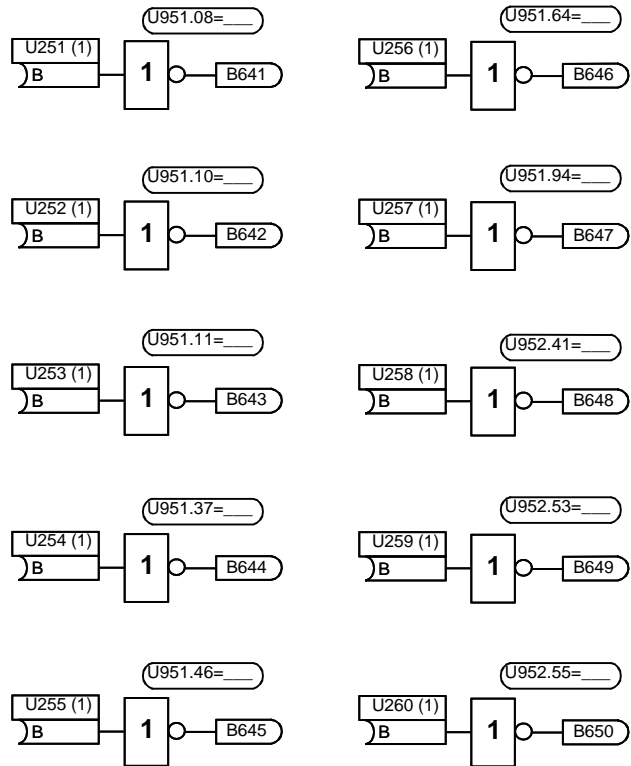

8 NAND elements with 3 inputs each {2μs}

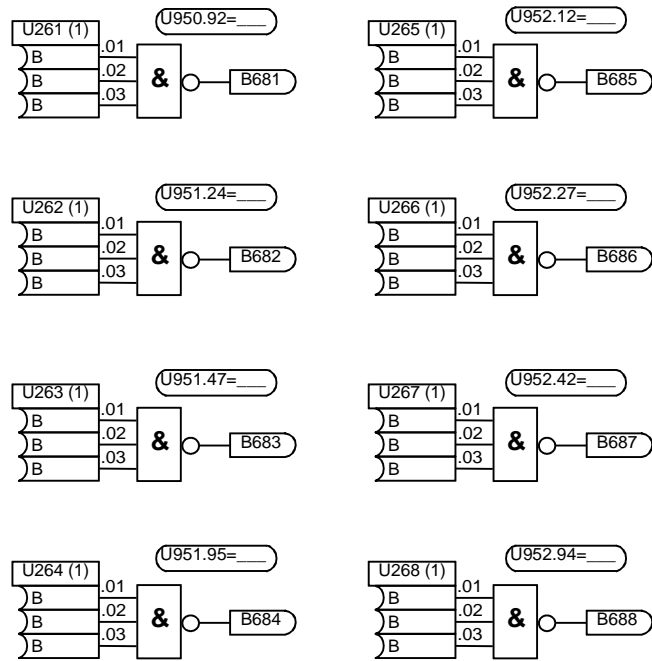

3 EXCLUSIVE OR elements {2μs}

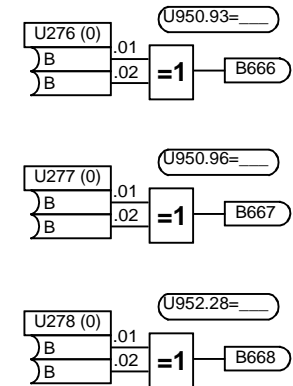

5 digital signal switches {2μs}

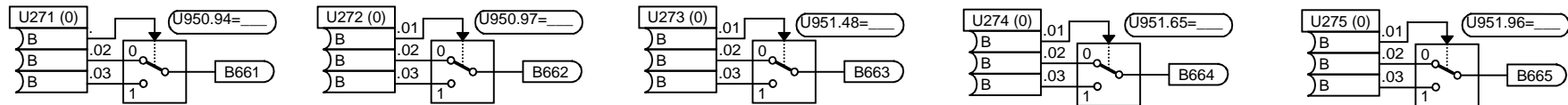

1

2

3

4

5

6

7

8

2 D flipflops {5μs}

Priority:
1. RESET
2. SET
3. STORE

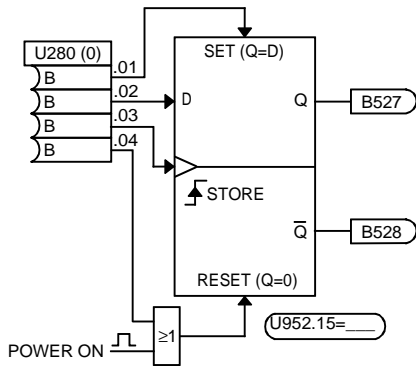
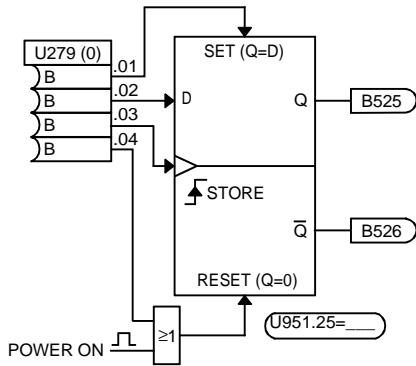

12 RS flipflops {3μs}

Priority:
1. RESET
2. SET

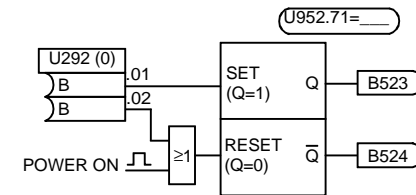
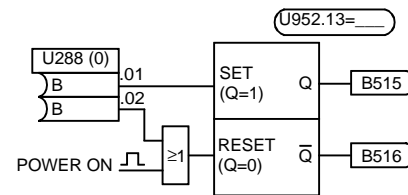
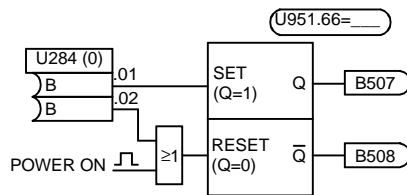
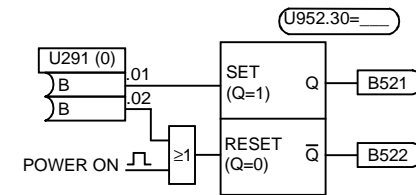
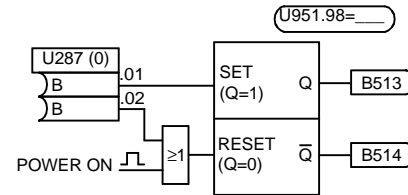
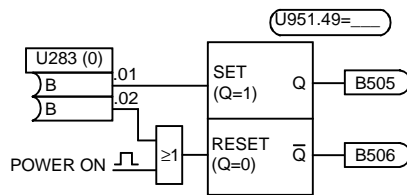
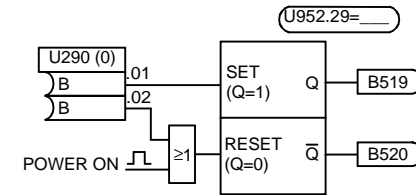
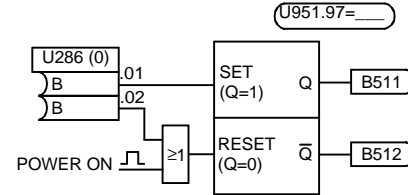
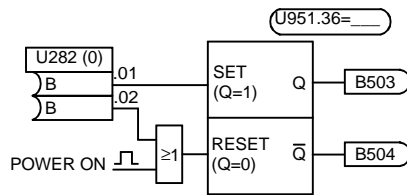
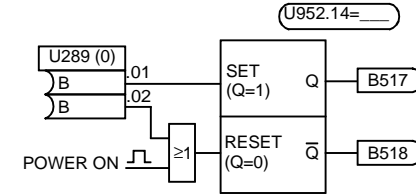
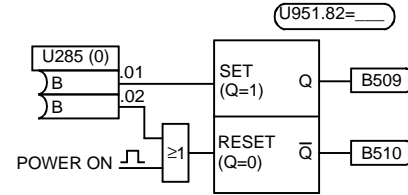
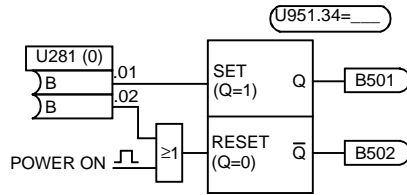

1

2

3

4

5

6

7

8

4 timers 0...60,000 s {11µs}

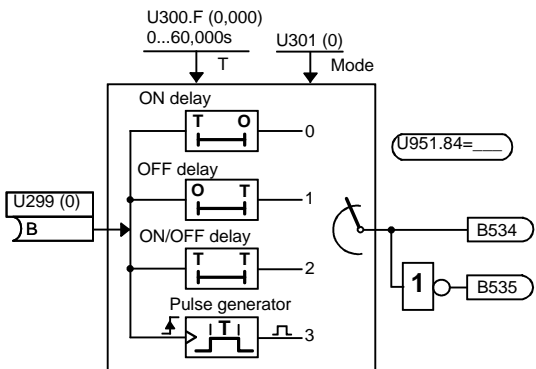
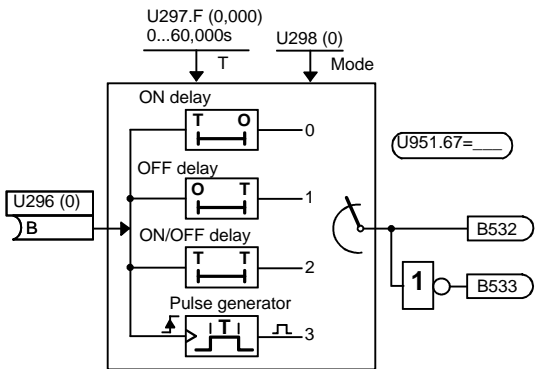
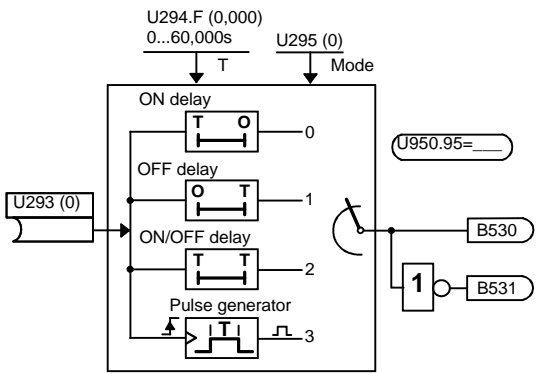

2 timers 0...600.00 s {11µs}

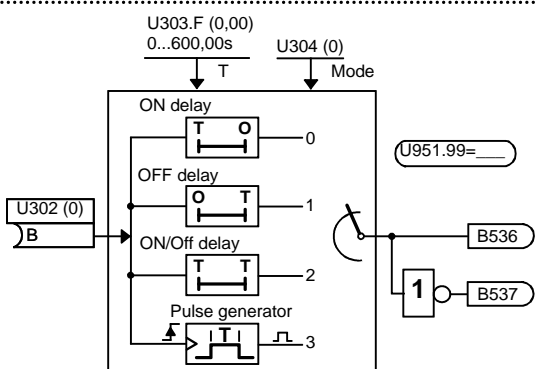
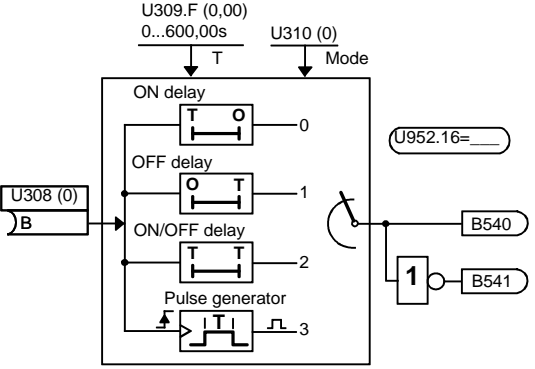
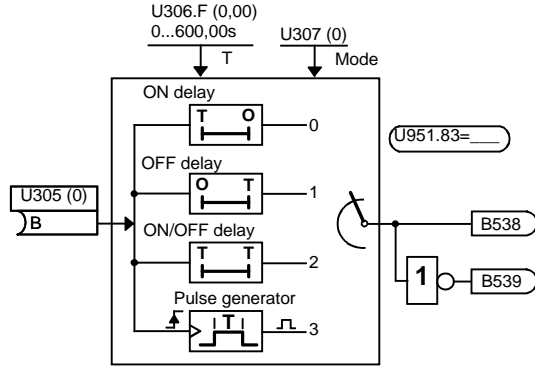

1 timer 0...60,000 s with adaption {21µs}

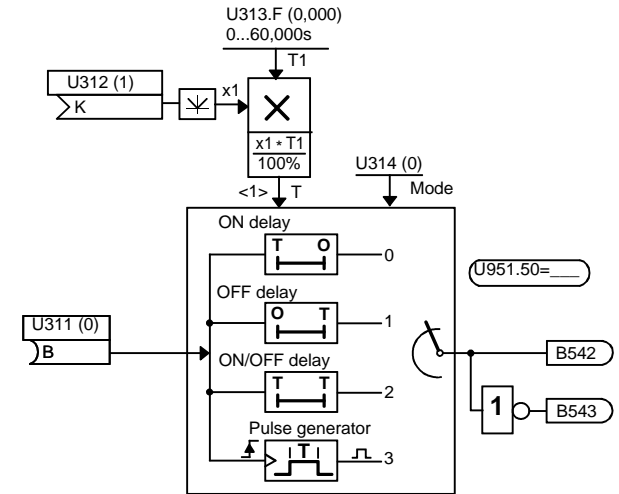

<1> Example: T1=40,000 s, x1=150%
 ==> effective time T=60 s
 T is limited to the value range 0...60,000s

Software counter 16 bit (maximum counting frequency: 1/sampling time) {8μs}

<3>

- Priority:
 1. Enable counter
 2. Set counter
 3. Stop counter
 4. Count up/down

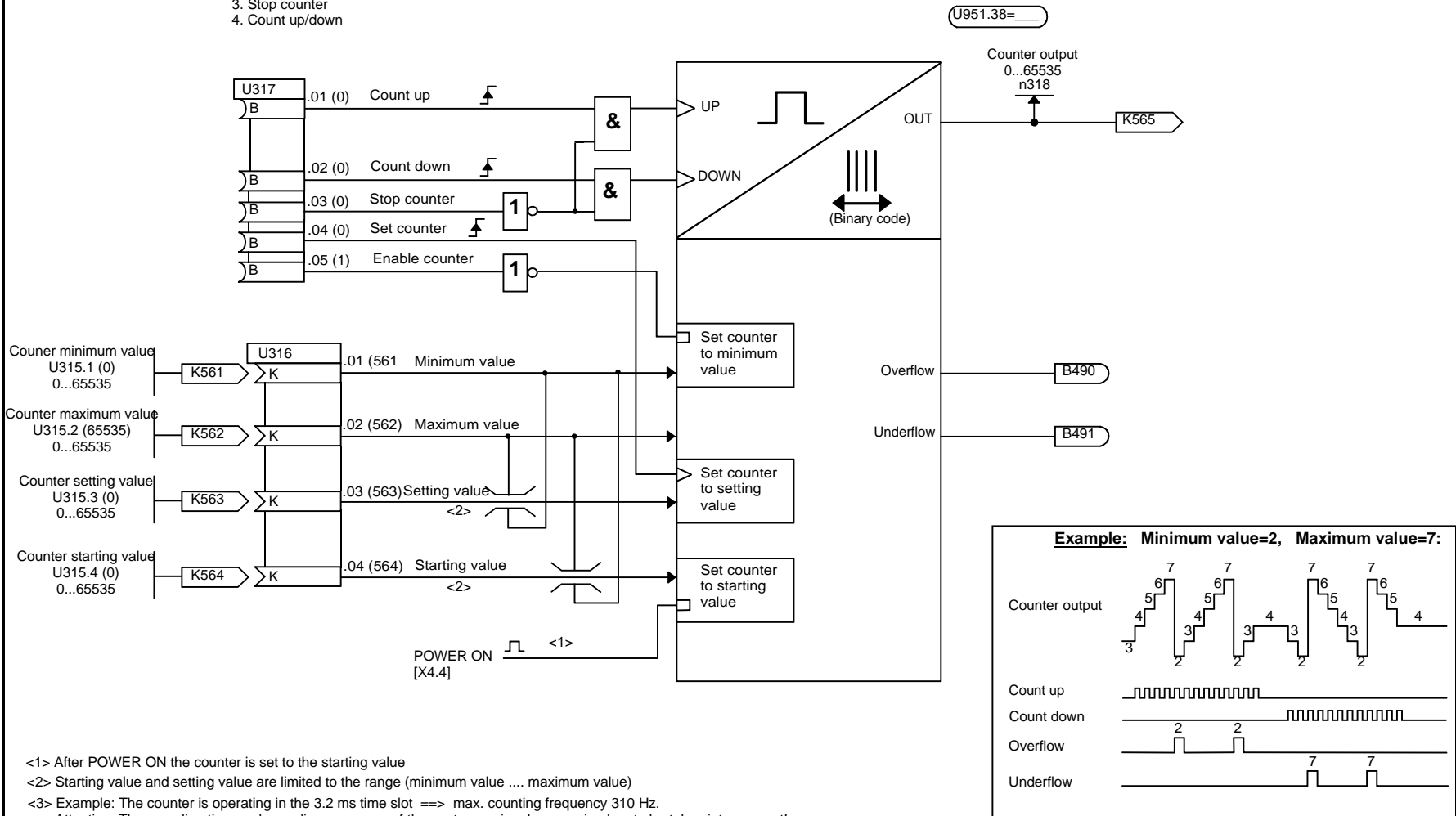

<1> After POWER ON the counter is set to the starting value
 <2> Starting value and setting value are limited to the range (minimum value maximum value)
 <3> Example: The counter is operating in the 3.2 ms time slot ==> max. counting frequency 310 Hz.
 Attention: The sampling time and sampling sequence of the upstream signal processing has to be taken into account!

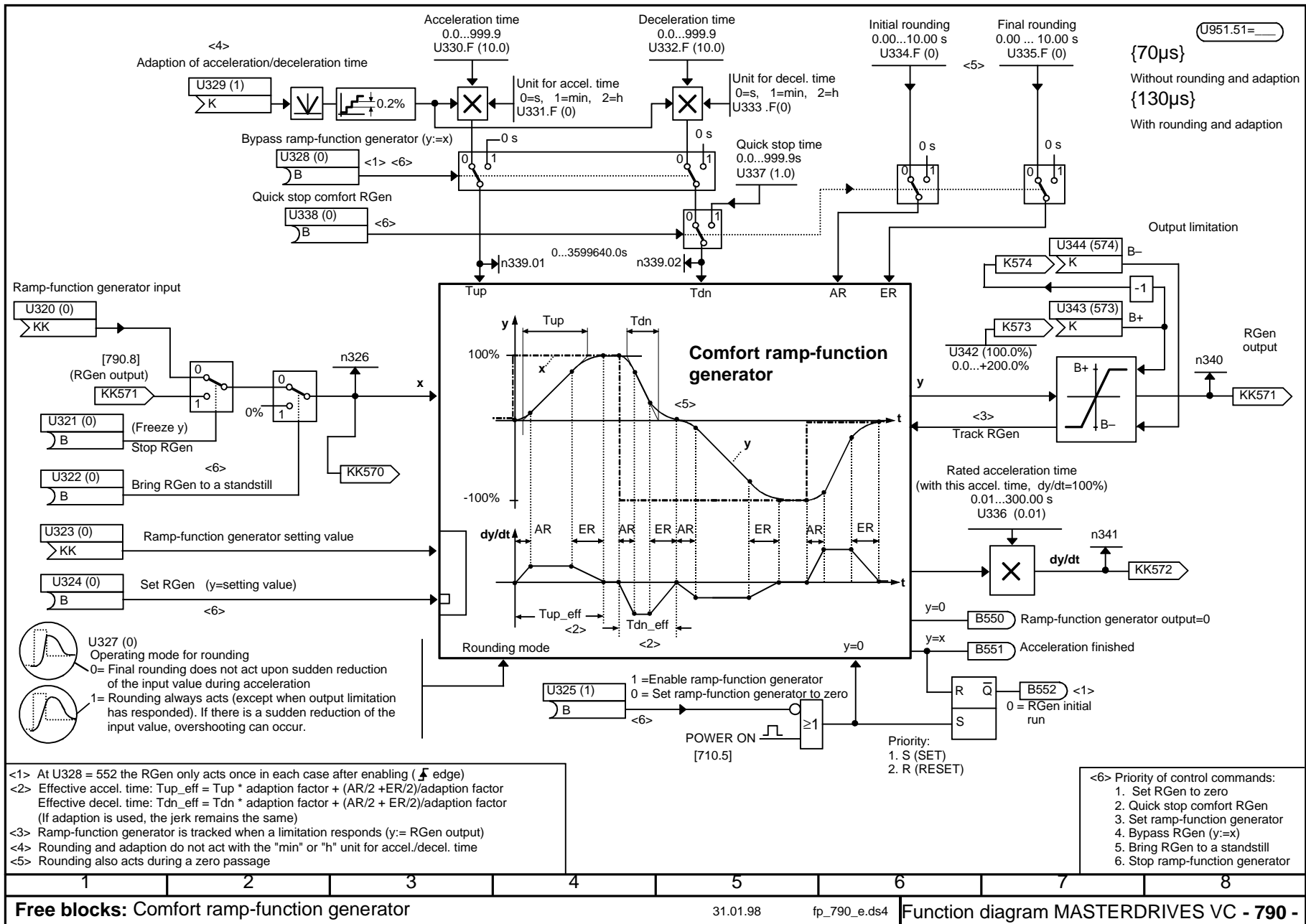

<1> At U328 = 552 the RGen only acts once in each case after enabling (\uparrow edge)
 <2> Effective accel. time: $T_{up_eff} = T_{up} \cdot \text{adaption factor} + (AR/2 + ER/2)/\text{adaption factor}$
 Effective decel. time: $T_{dn_eff} = T_{dn} \cdot \text{adaption factor} + (AR/2 + ER/2)/\text{adaption factor}$
 (If adaption is used, the jerk remains the same)
 <3> Ramp-function generator is tracked when a limitation responds ($y =$ RGen output)
 <4> Rounding and adaption do not act with the "min" or "h" unit for accel./decel. time
 <5> Rounding also acts during a zero passage

<6> Priority of control commands:
 1. Set RGen to zero
 2. Quick stop comfort RGen
 3. Set ramp-function generator
 4. Bypass RGen ($y = x$)
 5. Bring RGen to a standstill
 6. Stop ramp-function generator

Simple ramp-function generator

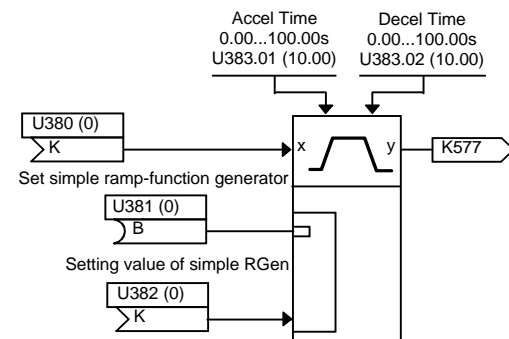

If you wish to use the simple ramp-function generator as a septoint ramp-function generator for the technology controller, the following signal connection can be recommended:

- Output of simple ramp-function generator ==> Setpoint input of technology controller (U352 = 577) [792.1]
- Technology controller disabled ==> Set simple ramp-function generator (U381 = 556) [792.3]
- Actual-value technology controller ==> Setting value of simple ramp-function generator (U382 = Wert von U355) [792.1]

U952.01=

{50 μs}

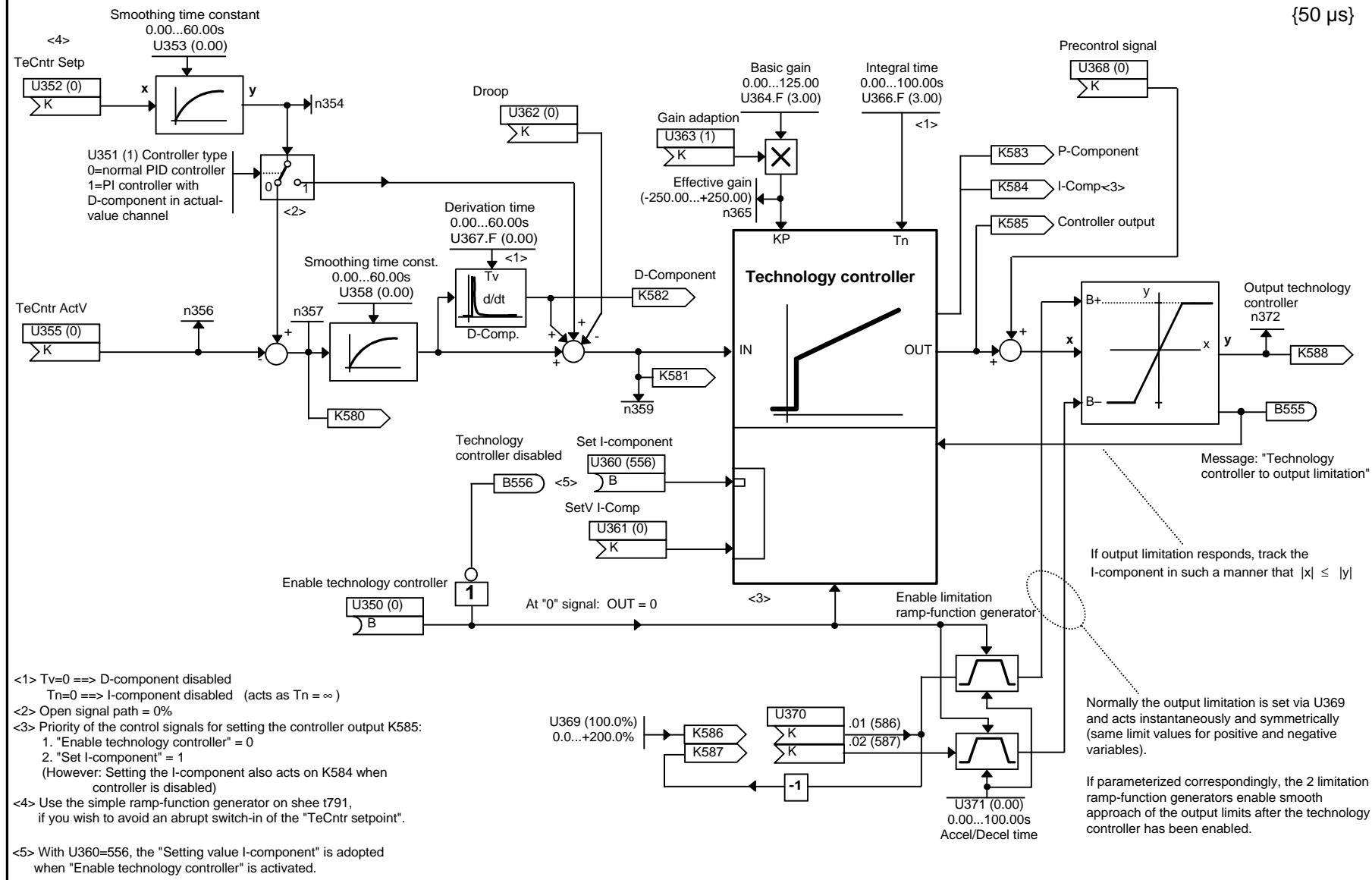

- <1> $T_v=0 \implies$ D-component disabled
 $T_n=0 \implies$ I-component disabled (acts as $T_n = \infty$)
- <2> Open signal path = 0%
- <3> Priority of the control signals for setting the controller output K585:
 1. "Enable technology controller" = 0
 2. "Set I-component" = 1
 (However: Setting the I-component also acts on K584 when controller is disabled)
- <4> Use the simple ramp-function generator on shiee t791, if you wish to avoid an abrupt switch-in of the "TeCntr setpoint".
- <5> With U360=556, the "Setting value I-component" is adopted when "Enable technology controller" is activated.

If output limitation responds, track the I-component in such a manner that $|x| \leq |y|$

Normally the output limitation is set via U369 and acts instantaneously and symmetrically (same limit values for positive and negative variables).

If parameterized correspondingly, the 2 limitation ramp-function generators enable smooth approach of the output limits after the technology controller has been enabled.

Wobble generator {83 μs}

Wobble amplitude: 0.00...+20.00 %
U393.F (0.00)

Wobble frequency: 0.1...120.0 Hz
U394.F (60.0)

Phase displacement: 0 ... 360 °el
U395.F (360)

P skip negative: 0.00...100.00 %
U396.F (0.00)

P skip positive: 0.00...100.00 %
U397.F (0.00)

Duty factor (Time portion of the rising edge): 0...100 %
U398.F (50)

